

Before beginning any service procedure, refer to section S of the 1996 626/MX-6 Body Electrical Troubleshooting Manual for air bag system service warnings.

LUBRICATION SYSTEM

(FS)

INDEX	D1- 2
OUTLINE	D1- 3
SPECIFICATIONS	D1- 3
TROUBLESHOOTING GUIDE	D1- 3
OIL PRESSURE	D1- 4
PREPARATION	D1- 4
INSPECTION	D1- 4
ENGINE OIL	D1- 6
INSPECTION	D1- 6
REPLACEMENT	D1- 6
OIL FILTER	D1- 7
PREPARATION	D1- 7
REPLACEMENT	D1- 7
OIL PAN	D1- 8
REMOVAL / INSTALLATION	D1- 8
OIL PUMP	D1-11
PREPARATION	D1-11
DISASSEMBLY / ASSEMBLY	D1-11
INSPECTION	D1-12

INDEX

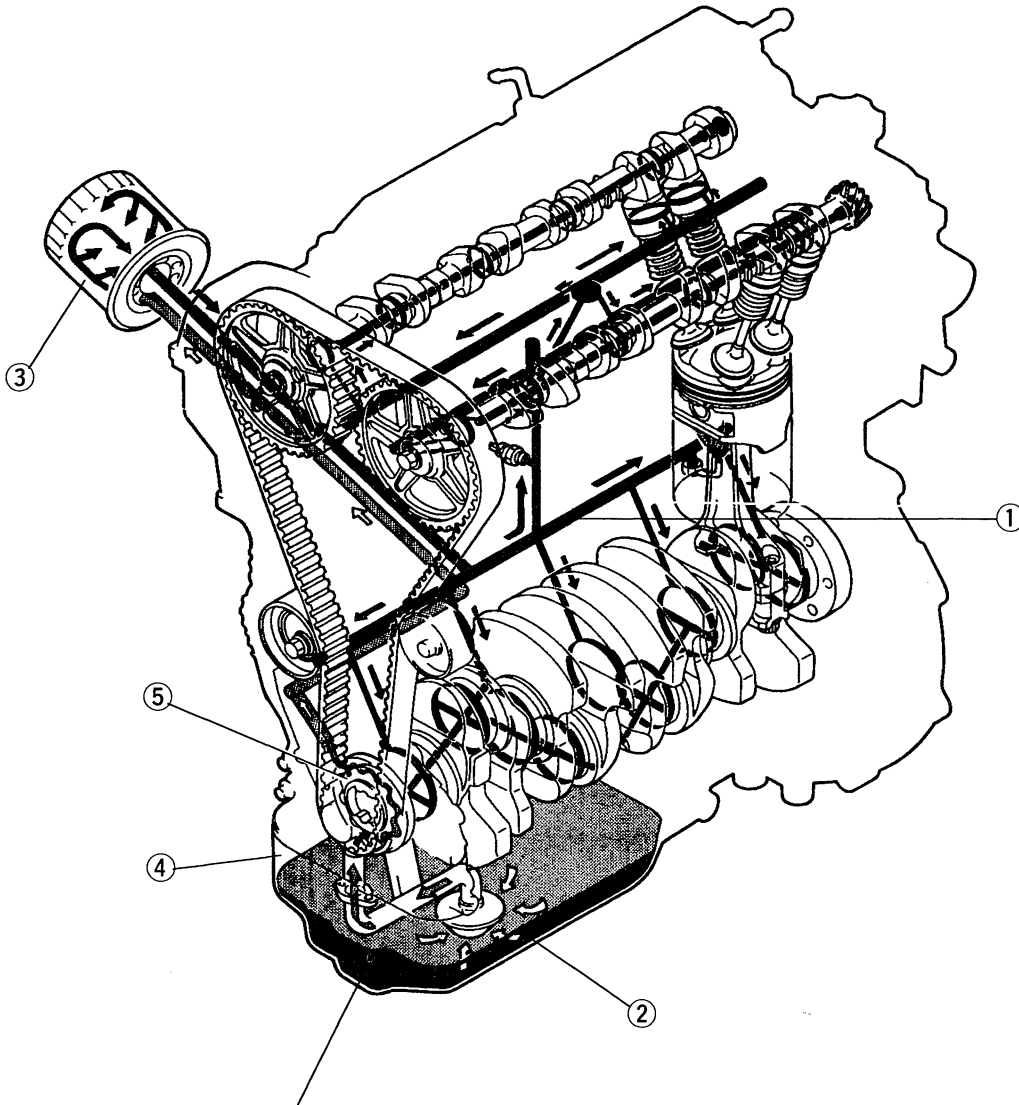

ENGINE OIL SPECIFICATION
API SERVICE SG, SH (ECII)
ILSAC
TOTAL CAPACITY
3.7 L {3.9 US qt, 3.3 Imp qt}

- 1. Oil pressure
Inspection page D1-4
- 2. Engine oil
Inspection page D1-6
Replacement page D1-6
- 3. Oil filter
Replacement page D1-7

- 4. Oil pan
Removal / Installation page D1- 8
- 5. Oil pump
Disassembly / Assembly page D1-11
Inspection page D1-12

OUTLINE

SPECIFICATIONS

Item		Engine	FS
Lubrication system			Force-fed type
Oil pump	Type		Trochoid gear
	Relief pressure	kPa {kgf/cm ² , psi}	442—539 {4.5—5.5, 64—78}
Oil filter	Type		Full-flow, paper element
	By-pass pressure differential	kPa {kgf/cm ² , psi}	79—117 {0.8—1.2, 12—17}
Oil pressure switch activation pressure		kPa {kgf/cm ² , psi}	14.8—27.4 {0.15—0.28, 2.14—3.98}
Oil capacity	Total (dry engine)	L {US qt, Imp qt}	3.7 {3.9, 3.3}
	Engine oil replacement	L {US qt, Imp qt}	3.3 {3.5, 2.9}
	Engine oil replacement (with oil filter)	L {US qt, Imp qt}	3.5 {3.7, 3.1}
Engine oil			API Service SG, SH (EC II) ILSAC

D1

Recommended SAE Viscosity

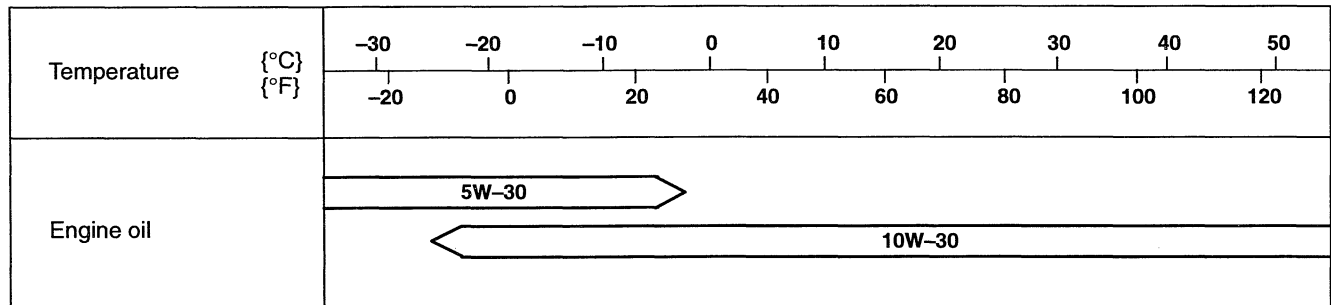

Anticipated ambient temperature range before succeeding oil change, °C {°F}

TROUBLESHOOTING GUIDE

Problem	Possible Cause	Remedy	Page
Engine hard starting	Improper engine oil	Replace	D1- 6
	Insufficient engine oil	Add oil	D1- 6
Excessive oil consumption	Oil working up or down in cylinder Oil leakage	Refer to section B1 Repair	—
Oil pressure drop	Insufficient engine oil	Add oil	D1- 6
	Oil leakage	Repair	—
	Worn and/or damaged oil pump rotor	Replace	D1-11
	Worn plunger (inside oil pump) or weak spring	Replace	D1-11
	Clogged oil strainer	Clean	—
	Excessive main bearing or connecting rod bearing clearance	Refer to section B1	—
Warning light illuminates while engine is running	Oil pressure drop Malfunction of oil pressure switch	As described above Refer to 1996 626/MX-6 Body Electrical Troubleshooting Manual	—
	Malfunction of electrical system	Refer to 1996 626/MX-6 Body Electrical Troubleshooting Manual	—

Warning

- Continuous exposure with USED engine oil has caused skin cancer in laboratory mice. Protect your skin by washing with soap and water immediately after this work.

OIL PRESSURE

PREPARATION

SST

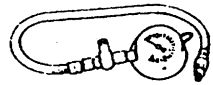
49 0187 280		For inspection of oil pressure
Gauge, oil pressure		

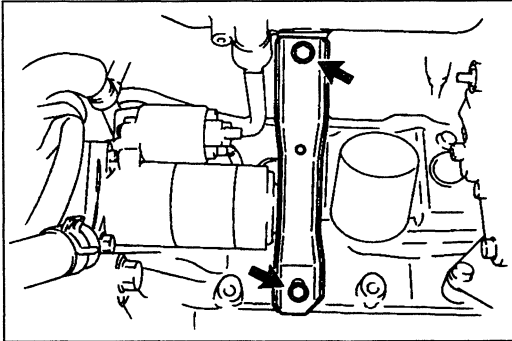

INSPECTION

1. Remove the intake manifold bracket.

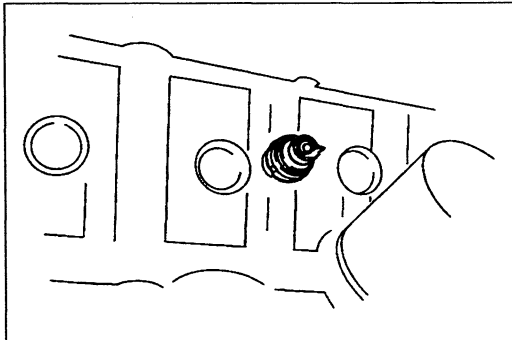

2. Remove the oil pressure switch.

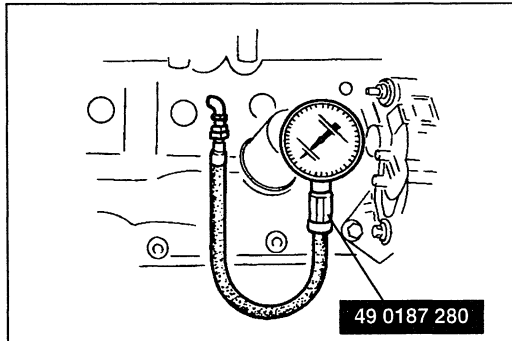

3. Screw the **SST** into the oil pressure switch installation hole.
4. Warm up the engine to normal operating temperature.
5. Run the engine at the specified speed, and note the gauge readings.

Note

- Oil pressure varies with oil viscosity and temperature.

Oil pressure: 393—490 kPa
{4.0—5.0 kgf/cm², 57—71 psi}—3,000 rpm

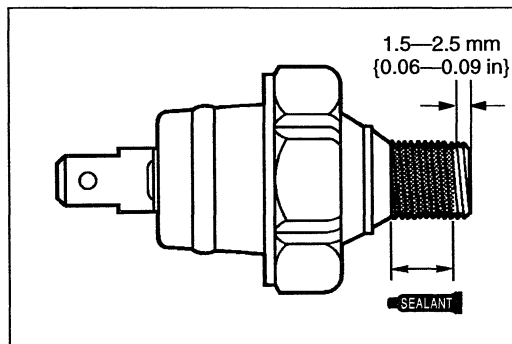

6. If the pressure is not as specified, check for the cause and repair as necessary.
 (Refer to Troubleshooting Guide, page D1-3.)
7. Apply silicone sealant to the oil pressure switch threads as shown.

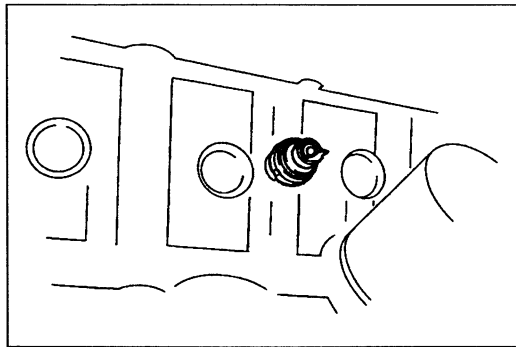

8. Remove the **SST** and install the oil pressure switch.

Tightening torque:

12—17 N·m {1.2—1.8 kgf·m, 8.7—13.0 ft·lbf}

D1

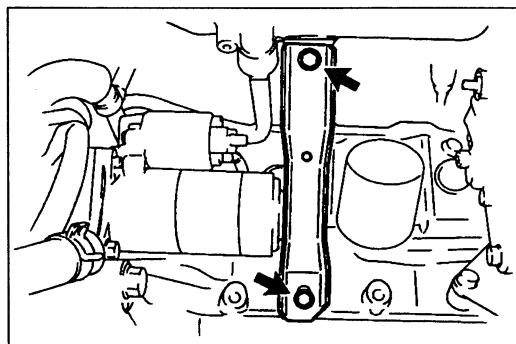

9. Install the intake manifold bracket.

Tightening torque:

38—51 N·m {3.8—5.3 kgf·m, 28—38 ft·lbf}

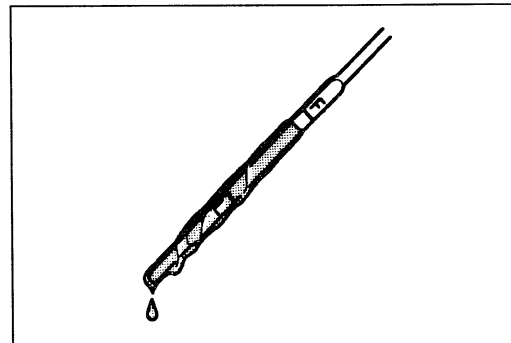
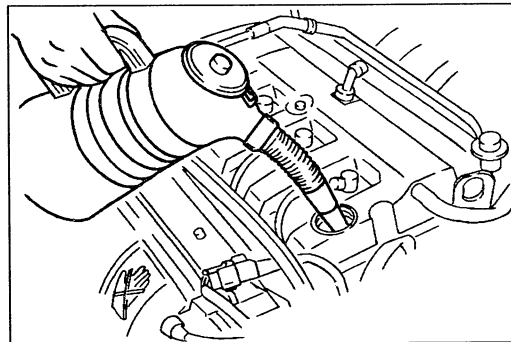
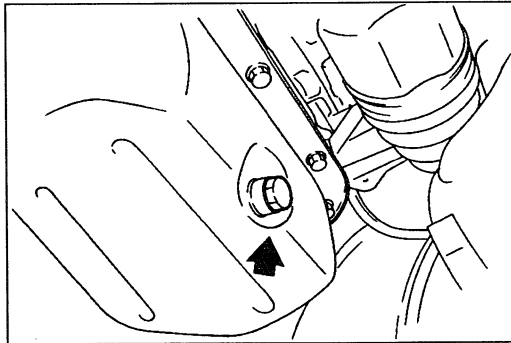
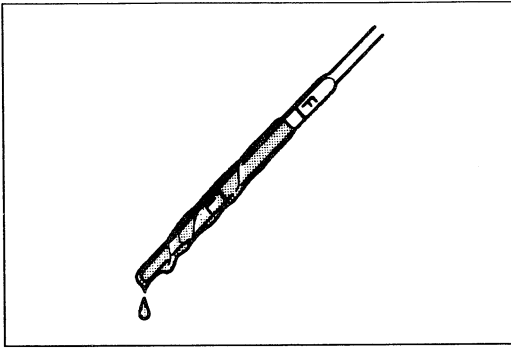

ENGINE OIL

INSPECTION

1. Be sure the vehicle is on level ground.
2. Warm up the engine to normal operating temperature and stop it.
3. Wait for five minutes.
4. Remove the dipstick and check the oil level and condition.
5. Add or replace oil as necessary.

Note

- The distance between the L and F marks on the dipstick represents 1.0 L {1.1 US qt, 0.9 Imp qt}.

REPLACEMENT

Warning

- **When the engine and the oil are hot, they can badly burn. Don't burn yourself with either.**

1. Remove the oil filler cap and the oil pan drain plug.
2. Drain the oil into a container.
3. Install the drain plug.

Tightening torque:

30—41 N·m {3.0—4.2 kgf·m, 22—30 ft·lbf}

4. Refill the engine with the specified type and amount of engine oil.

Oil capacity

L {US qt, Imp qt}

Total (dry engine)	3.7 {3.9, 3.3}
Engine oil replacement	3.3 {3.5, 2.9}
Engine oil replacement (with oil filter)	3.5 {3.7, 3.1}

5. Refit the oil filler cap.
6. Run the engine and check for leaks.
7. Check the oil level and add oil if necessary.

OIL FILTER

PREPARATION

SST

<p>49 G014 001</p> <p>Oil filter wrench</p>		<p>For removal / installation of oil filter</p>
---	---	---

D1

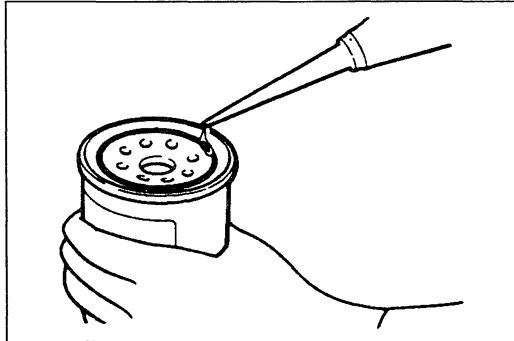

REPLACEMENT

1. Remove the oil filter by using the **SST**.
2. Use a clean rag to wipe off the mounting surface on the engine.
3. Apply clean engine oil to the O-ring of the new filter.

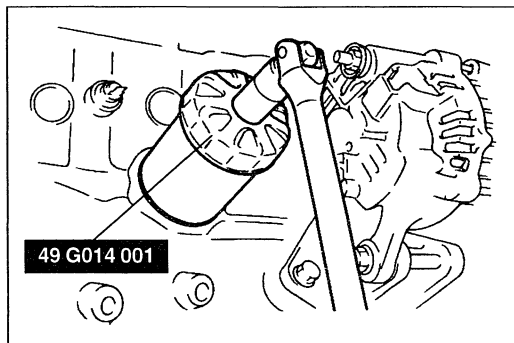

4. Install the oil filter and tighten it by hand until the O-ring contacts the cylinder block.
5. Tighten the filter 1 and 1/6 turns by using the **SST**.

Tightening torque:

14—17 N·m {1.4—1.8 kgf·m, 11—13 ft·lbf}

6. Start the engine and check for leaks.
7. Check the oil level and add if necessary.

Oil filter capacity: 0.2 L {0.2 US qt, 0.2 Imp qt}

OIL PAN

REMOVAL / INSTALLATION

1. Disconnect the negative battery cable.
2. Drain the engine oil. (Refer to page D1-6.)
3. Remove in the order shown in the figure, referring to **Removal Note**.
4. Install in the reverse order of removal, referring to **Installation Note**.

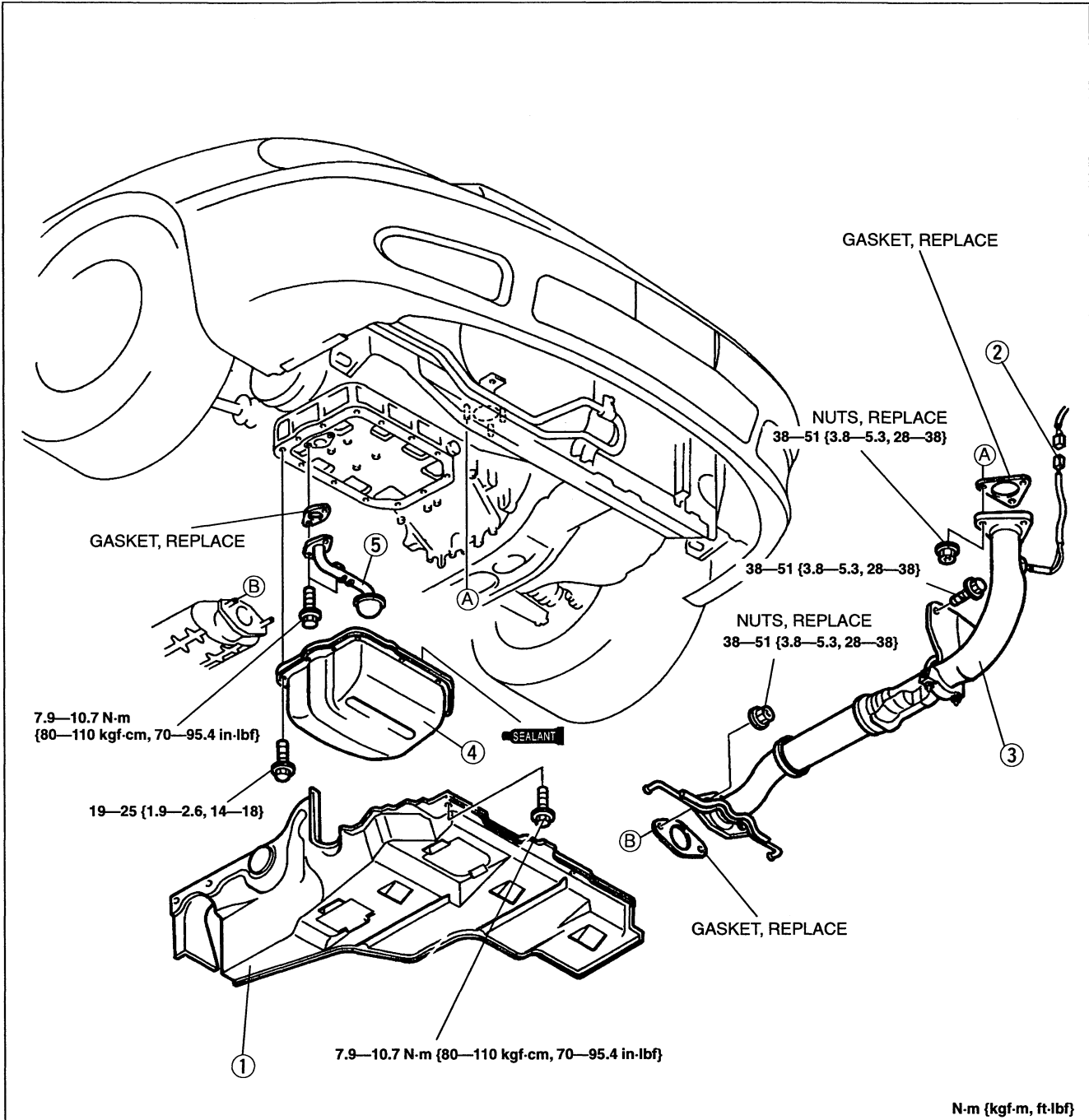

1. Splash shield
Removal Note page D1-9
Installation Note page D1-9

5. Oil strainer
Removal Note page D1-9
Installation Note page D1-9

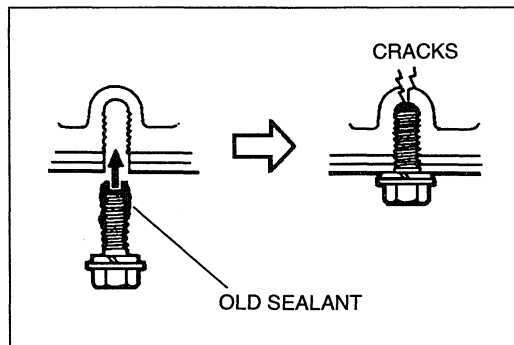
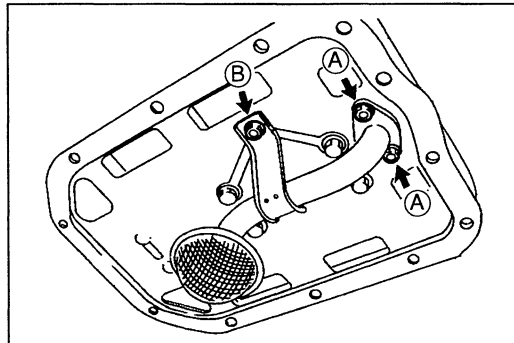
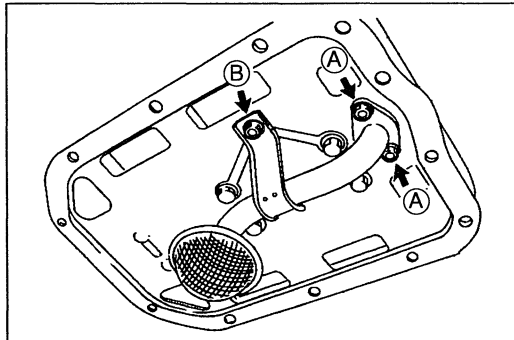
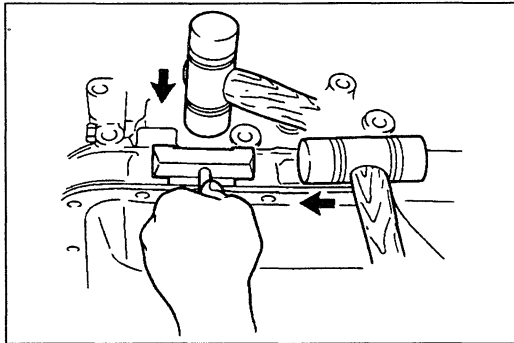
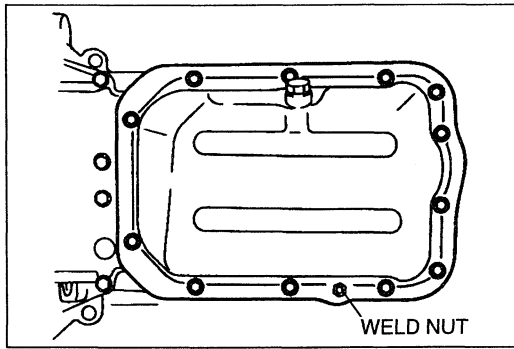

Removal Note

Oil pan

1. Remove the oil pan mounting bolts.

Caution

- Pry tools can easily scratch the oil pan upper block and oil pan contact surfaces. Prying off the oil pan can also easily bend the oil pan flange. Refer to the following instructions before removing the oil pan.

D1

2. Remove the sealant on the bolt threads.
3. Screw in an oil pan bolt in the weld nut hole to make a small gap between the oil pan upper block and the oil pan.
4. Separate the oil pan from the oil pan upper block by using a scraper or a separator tool.
5. Remove the oil pan.

Oil strainer

1. Remove bolt (B).
2. Remove bolts (A).
3. Remove the oil strainer and gasket.

Installation Note

Oil strainer

1. Install the oil strainer with a new gasket.
2. Tighten the bolts marked (A) first.

Tightening torque:

7.9—10.7 N·m {80—110 kgf·cm, 70—95.4 in·lbf}

Oil pan

Caution

- If the bolts are reused, remove the old sealant from the bolt threads. Tightening a bolt that has old sealant on it can cause thread damage.

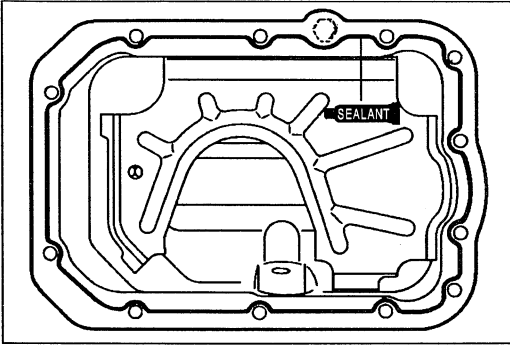

1. Remove all foreign material from the contact surfaces.
2. Apply silicone sealant to the oil pan as shown.

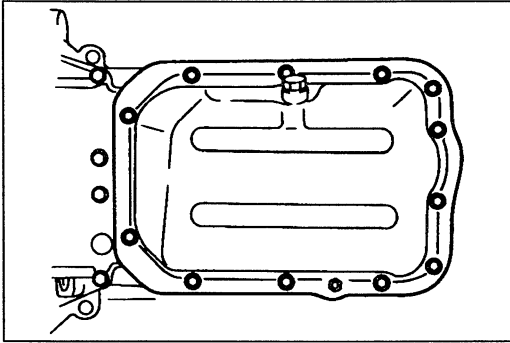

3. Install the oil pan within five minutes of applying the sealant.

Tightening torque:

19—25 N·m {1.9—2.6 kgf·m, 14—18 ft·lbf}

Steps After Installation

1. Fill with the specified amount and type of engine oil. (Refer to page D1-6.)
2. Connect the negative battery cable.
3. Start the engine and check for leaks.
4. Check the oil level and add oil if necessary.

OIL PUMP

PREPARATION

SST

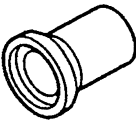
49 H010 401		For installation of front oil seal
Installer, oil seal		

DISASSEMBLY / ASSEMBLY

1. Disassemble in the order shown in the figure, referring to **Disassembly Note**.
2. Assemble in the reverse order of disassembly, referring to **Assembly Note**.

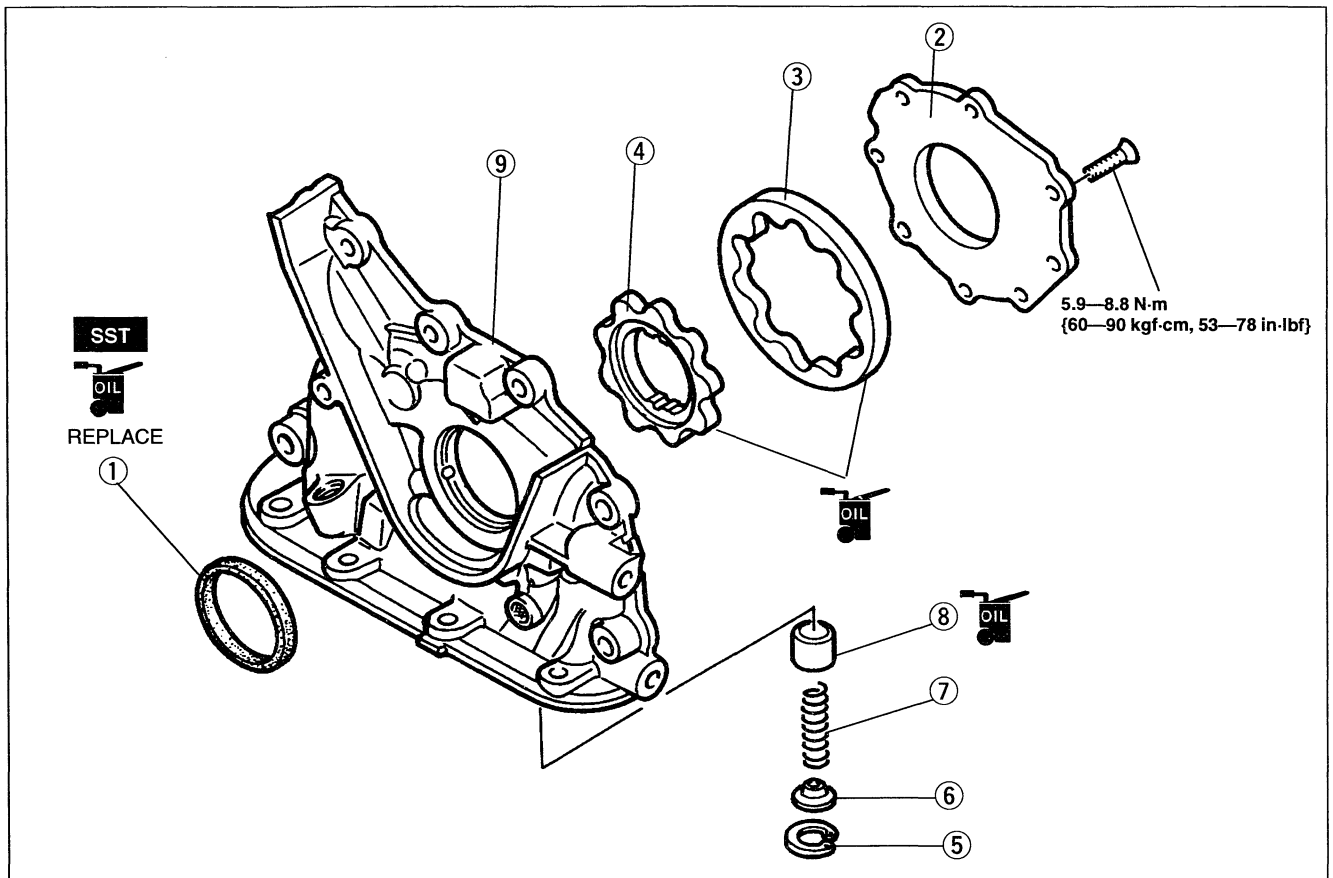

- | | |
|---|--|
| <p>1. Oil seal
 Disassembly Note page D1-12
 Assembly Note page D1-13</p> | <p>4. Inner rotor
 Inspection page D1-12
 Assembly Note page D1-13</p> |
| <p>2. Pump cover
 Disassembly Note page D1-12
 Assembly Note page D1-13</p> | <p>5. Snap ring
 6. Spring seat
 7. Pressure spring
 Inspection page D1-12</p> |
| <p>3. Outer rotor
 Inspection page D1-12
 Assembly Note page D1-13</p> | <p>8. Control plunger</p> |

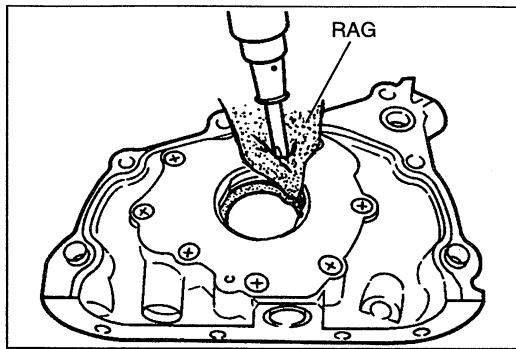
**Disassembly Note****Oil seal**

Remove the oil seal with a screwdriver protected with a rag.

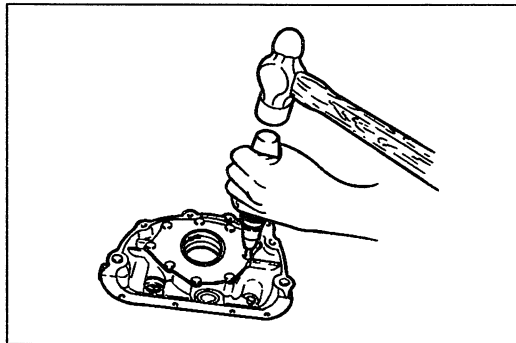
**Pump cover**

1. Remove the pump cover mounting bolts with an impact screwdriver.
2. Remove the pump cover.

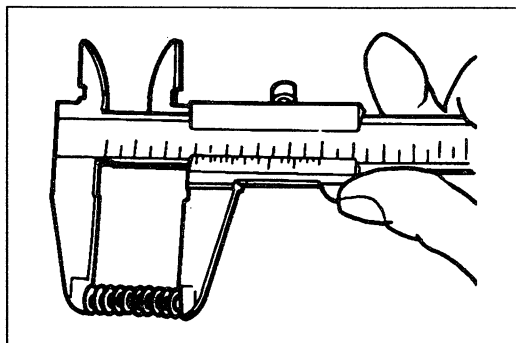
**INSPECTION****Pressure spring**

1. Inspect the spring for weakness and damage.
2. Measure the free length. Replace the spring if necessary.

Free length: 46.79 mm {1.842 in}

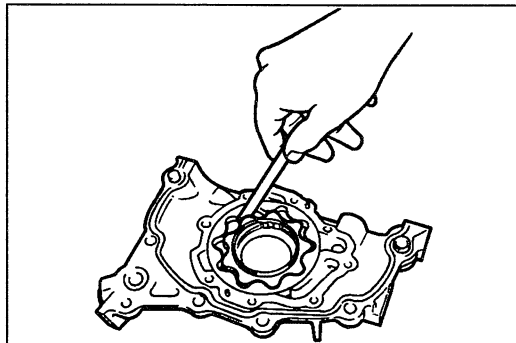
**Rotor Clearance**

Measure the following clearance. Replace the rotor if necessary.

Inner rotor-to-tooth tip clearance:

0.02—0.18 mm {0.0008—0.0070 in}

Maximum: 0.200 mm {0.0079 in}

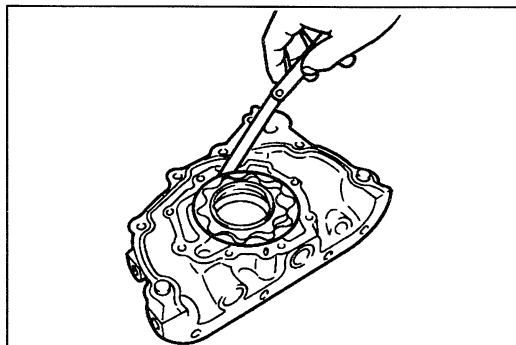
**Outer rotor-to-pump body clearance:**

0.113—0.186 mm {0.0045—0.0073 in}

Maximum: 0.210 mm {0.0083 in}

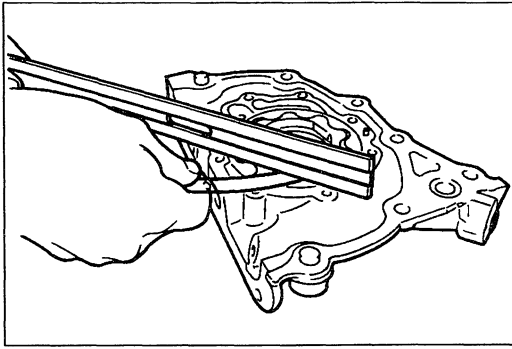
**Side clearance:**

0.035—0.095 mm {0.0014—0.037 in}

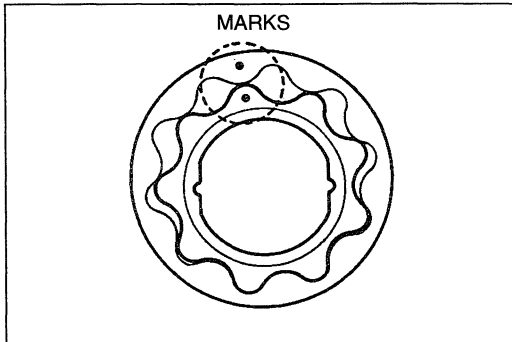
Maximum: 0.120 mm {0.0047 in}**Assembly Note****Inner and outer rotor**

1. Apply clean engine oil to the friction surface of the pump body and the rotors.
2. Install the inner and outer rotors into the oil pump body with the marks aligned as shown.

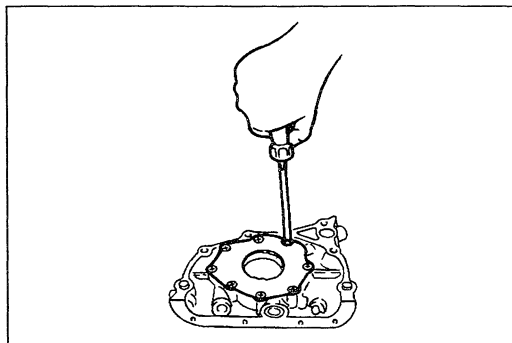
**Pump cover**

1. Install the pump cover.

Tightening torque:

5.9—8.8 N·m {60—90 kgf·cm, 53—78 in·lbf}

2. Verify that the inner rotor turns smoothly when turned by hand.

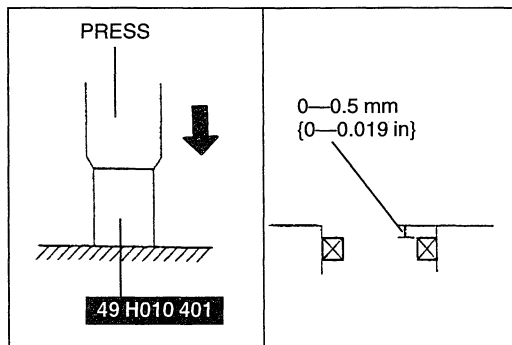
**Oil seal**

1. Apply clean engine oil to the new oil seal.
2. Install the oil seal into the oil pump body by hand.
3. Press the oil seal into the oil pump body by using the SST.